

Hills Quarry Products has an extensive vehicle fleet featuring the latest technology which is strategically located to provide a high quality service to customers across central and southern England.

With vehicles ranging from four-wheeled mixers to 29-tonne articulated tippers, Hills Quarry Products is able to deliver aggregates, concrete, screed and site clearance services to projects of all sizes.

## MIXERS

### 4-wheeled mixer

Max vehicle weight 18T

Max load capacity 4m<sup>3</sup>

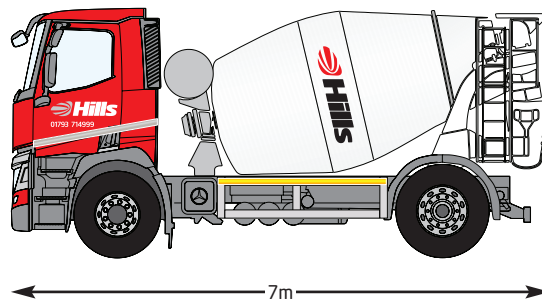
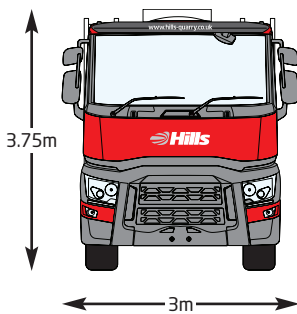

### 6-wheeled mixer

Max vehicle weight 26T

Max load capacity 6m<sup>3</sup>

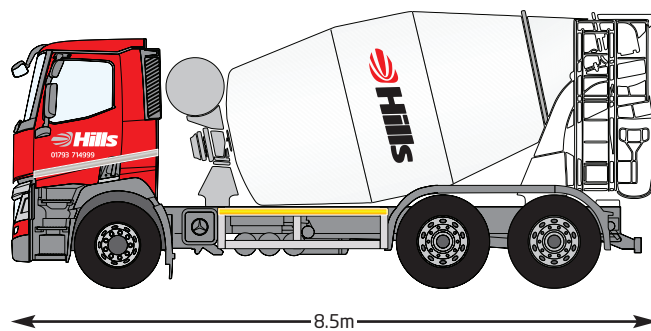
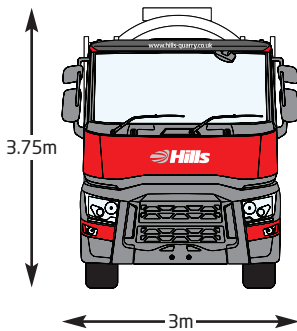

### 8-wheeled mixer

Max vehicle weight 32T

Max load capacity 8m<sup>3</sup>

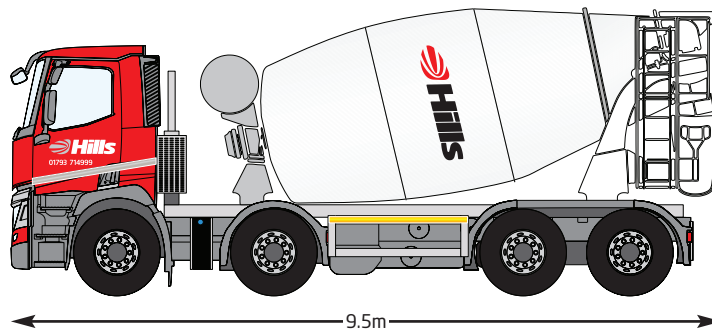
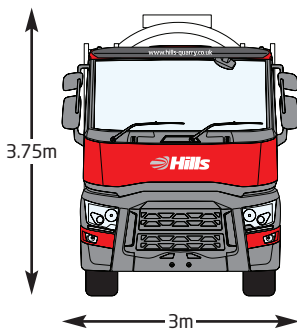

# Vehicle guide

## TIPPERS

### 4-wheeled tipper

Max vehicle weight 18T

Max load capacity 10T

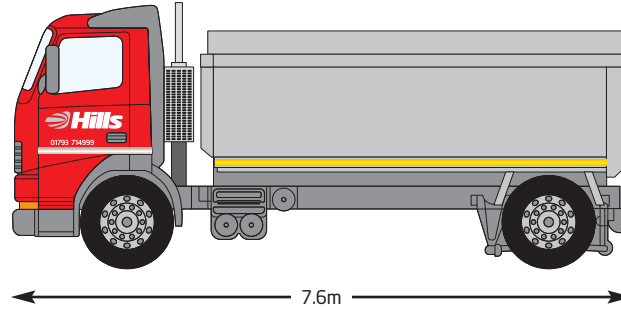
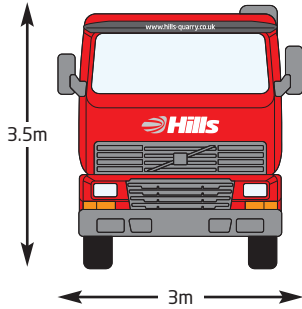

### 6-wheeled tipper

Max vehicle weight 26T

Max load capacity 16T

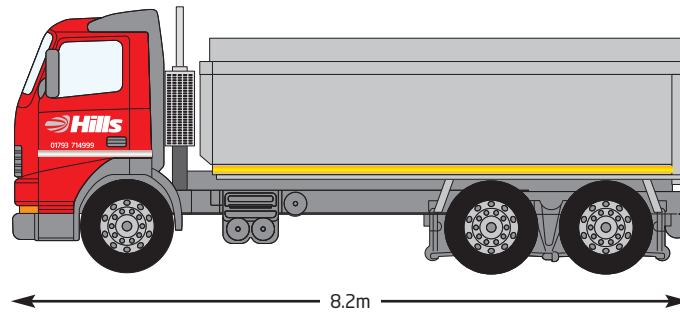
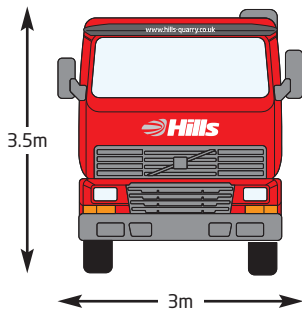

### 8-wheeled tipper

Max vehicle weight 32T

Max load capacity 20T

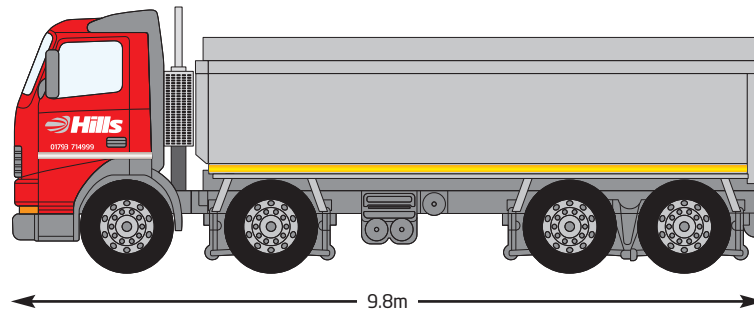
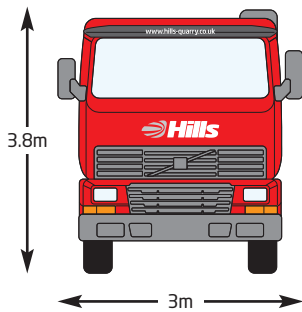

### Artic

Max vehicle weight 44T

Max load capacity 29T

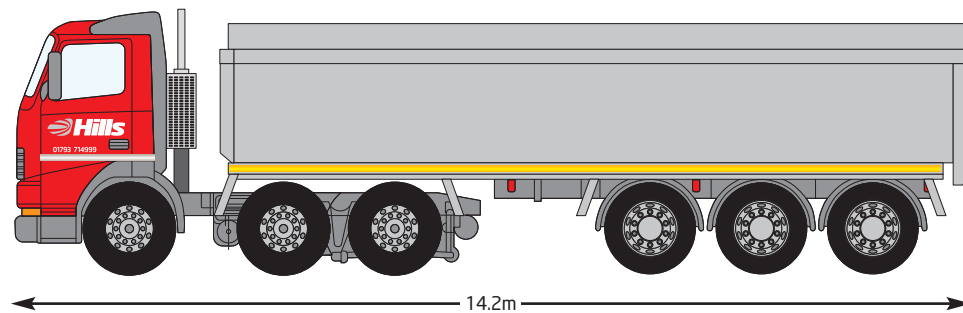
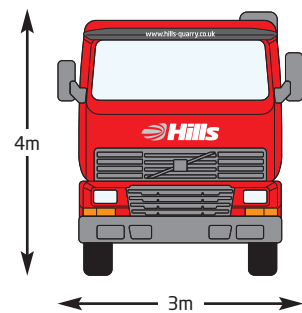

In order to deliver a high quality service all vehicles will require safe and easy access to site.



[www.hills-quarry.co.uk](http://www.hills-quarry.co.uk)

### Hills Quarry Products Limited

Wiltshire House, County Park Business Centre  
Shrivenham Road, Swindon SN1 2NR

Tel: 01793 714999

Fax: 01793 486825

Email: [info@hills-group.co.uk](mailto:info@hills-group.co.uk)